

Vertical Cryogenic Storage Tanks for Liquid Natural Gas

VT^{LNG} SERIES



The new VT^{LNG} range of cryogenic tanks combines safety, flexibility and easy economical operation. The VT^{LNG} series includes 21 models with features industrial gas producers and users want, but could not get until now. Primary among these features is a high performance, standard design with a wide range of options to meet most special needs.

The VT^{LNG} series is designed for long-term storage of liquefied natural gas. The VT^{LNG} series is available in capacities from 3.000 to 60.000 liters and maximum allowable working pressures of 19, and 12,6 bar. All VT^{LNG} tanks are produced in accordance with PED, European Norms, AD 2000, or other national pressure vessel codes, as required. Tanks outside this range are available upon request.

Finally, Ferox manufactures customized vertical and horizontal storage tanks with capacities up to 500.000 liters, as well as supplies vaporizers, vacuum insulated pipeline and other components needed to create a complete "customer" installation.

Benefits of the VT^{LNG} Series

Inner Vessel - stainless steel for cryogenic temperatures with optimized design for lighter weight

Outer Jacket - a combined leg and lifting lug system designed for safe transport, easy lifting and low cost erection using a single crane

Insulation - a proven high quality vacuum-perlite system with molecular sieve adsorber

Piping - stainless steel piping for reliability and long life, ergonomically arranged workplace, flow diagram and gauges at eye level, easily accessible valves and safety relief valve outlets directed away from the operating area

Valves - standard with stainless steel bodies and welded connections

Pressure Control - an easily adjustable multifunction regulator serves as pressure regulator, economiser and thermal-relief valve. An aluminum stainless steel cored pressure building coil is standard

Instrumentation - high quality pressure gauge and differential pressure contents gauge are standard with optional switches, transmitter and/or telemetry unit

Safety - tanks are equipped with dual relief valves with a variety of options, including additional relief valves and/or rupture discs, all vents to atmosphere are led to stack, going to top of tank

PED Design - Ferox has been manufacturing cryogenic tanks in accordance with the new European code "PED", the Pressure Equipment Directive, since 1999.

Pump Options - pump connection with a thermo-siphon is available as an option

Cleanliness - all tanks and their components are cleaned and certified for oxygen service

Outer Finish - choice of two durable corrosion resistant white paints, including a new low VOC paint or a standard 2-stage epoxy-polyurethane paint

Transport - rugged internal supports allow for safe transportation by road, rail or container



Innovation. Experience. Performance.™

Technical Specification

Type	VT ^{LN} G ...	2	3	5	6	9	11	16	21	25	26	31	37	43	32	41	50	60	
Gross volume	Liters	2000	3400	4700	6100	8700	11200	15900	20700	25400	25700	31600	37500	43400	31900	41100	50300	59500	
Net capacity (90% filling) ¹⁾	Liters	1800	3060	4230	5490	7830	10080	14310	18630	22860	23130	28440	33750	39060	28710	36990	45270	53550	
	LNG ²⁾	kg	850	1440	1990	2590	3690	4740	6730	8760	10750	10880	13370	15870	18360	13500	17390	21280	25170
Daily evaporation rate LNG ³⁾	%/d	0,45	0,39	0,29	0,28	0,25	0,24	0,22	0,21	0,19	0,17	0,15	0,15	0,14	0,14	0,13	0,12	0,11	
Weight, empty	19 barg	kg	2700	3400	4000	4700	6000	7000	8800	10600	12500	14200	16700	19100	21600	15900	19200	22500	25700
	12,6 barg	kg	N/A	N/A	N/A	N/A	N/A	N/A	N/A	N/A	N/A	N/A	N/A	N/A	N/A	14700	17600	20600	23400
Diameter (D)	mm				1800			2200			2500			3000					
Overall width (A)	mm				2050			2200			2500			3000					
Overall depth (B)	mm				2100			2240			2540			3040					
Height ⁴⁾ (H)	mm	3140	3940	4960	5770	7600	6100	7930	9760	11590	9880	11720	13540	15370	8320	10150	11980	13810	

Notes:

- 1) Filling 90% (equilibrium state at 1,013 bar)
- 2) Calculated for density 470 kg/m³, can vary with composition of LNG
- 3) Based on pressure 100 kPa and 15°C ambient temperature
- 4) Tanks with thermosiphon are approx. 790 mm higher
- 5) Design and specifications are subject to change without prior notice.

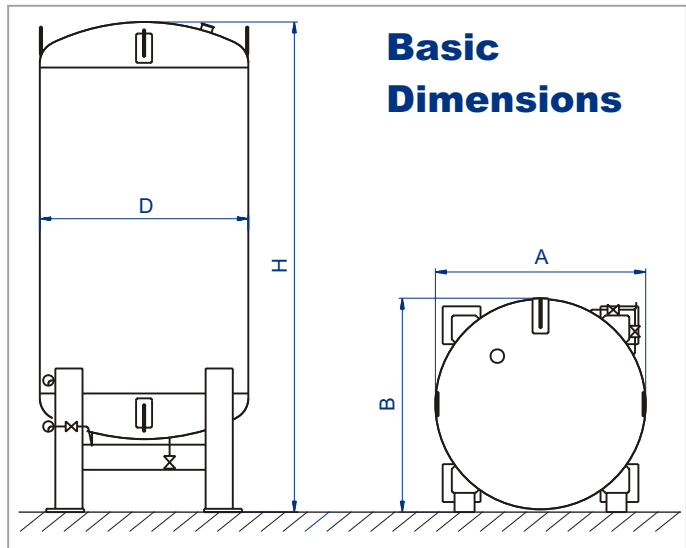

Basic Dimensions

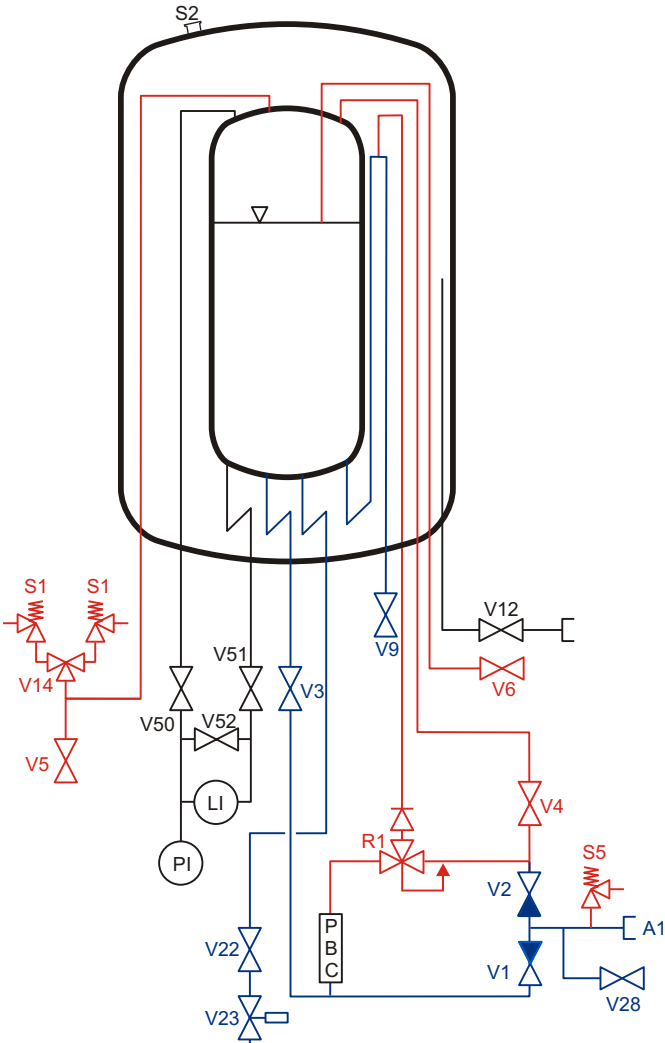

Nomenclature (standard model — not all options shown)

- A1 Fill connection
- LI Level indicator
- PBC Pressure building coil
- PI Pressure indicator
- R1 Pressure control valve / Economizer
- S1 Safety valves, inner vessel
- S2 Vacuum safety device
- S5 Thermal relief valve, fill line
- V1 Bottom fill valve
- V2 Top fill valve
- V3 Isolating valve, bottom fill
- V4 Isolating valve, top fill
- V5 Valve, vapor vent / gas outlet
- V6 Valve, trycock
- V9 Valve, external vaporizer
- V12 Valve, evacuation
- V14 Valve, safety relief selection
- V22 Valve, liquid outlet (VT^{LN}G11-VT^{LN}G60)
- V23 Pneumatic actuated valve for remote shut-off
- V28 Valve, fill line drain
- V50 Valve, LI vapor phase
- V51 Valve, LI liquid phase
- V52 Valve, LI equalization